

Specifications of a typical Mikada Cabinet

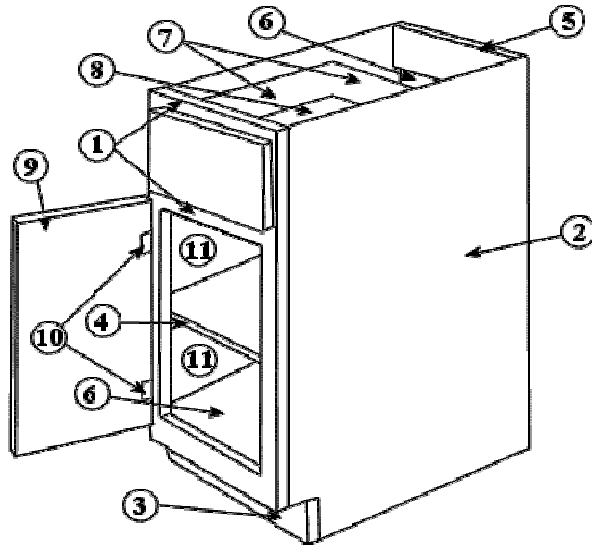

1. Face frames are #2 white pine covered with high pressure laminate.
2. End panels are 1/2" seal coated 30 gram paper particle board, dadoed into face frame.
3. Toe kicks are #2 white pine.
4. Shelves are 1/2" seal coated 30 gram paper particle board taped on all exposed edges and dadoed into sides.
5. Nailers are #2 white pine.
6. Backs are 1/8" masonite hardboard. Bottoms of base cabinets and vanity cabinets are all print-sealed 1/2" seal coated 30 gram paper particle board.
7. Drawer sides are 1/2" or 7/16" medium density print-sealed fiberboard rollers with dual teflon guides.
8. Drawer bottoms are print-sealed 3/16" or 1/8" masonite hardboard glued at rabbetts and hot glued on bottom sides.
9. Door and drawer fronts are thermal-fused melamine on 5/8" medium density fiberboard or particle board, with beveled or PVC taped finished edges (Thermofoil Vacuum Sealed and Hardwood Doors are also available).
10. Hinges are a semi-concealed or fully concealed (currently we use Ferrari concealed hinges).
11. Interiors are coated 30 gram paper.